

1/10/2008

FOLD-DOWN HITCH BALL

**DO NOT EXCEED YOUR VEHICLE'S RATED TOWING CAPACITY!
(CUTTING OF BED RAIL SUPPORTS MAY BE NECESSARY ON SOME MODELS.)**

WARNING DO NOT invert ball when carrying heavy loads on 2 wheel drive trucks. The ball may hit the top of the differential, brake lines, or sensors. **(Note: Do not invert ball on any Toyota Tundra models)**

LOCATION AND FLOOR CUT-OUT

1. The hitch must be centered between the sides of the truck bed about 2"- 6" in front of the rear axle for proper weight distribution (**Figure 1**).

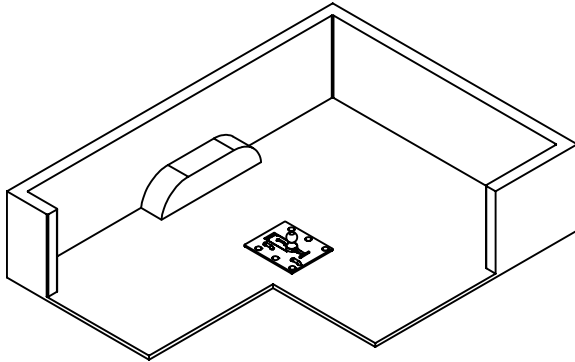

FIGURE 1

CAUTION: Remember to allow ample clearance between your trailer and the cab corner of the truck when making sharp turns.

2. Locate and mark the area for the center of the hitch ball.
3. Mark an 7 1/2" x 11" cut-out to be used for flush mounting the fold-down hitch ball. (**Figure 2**).

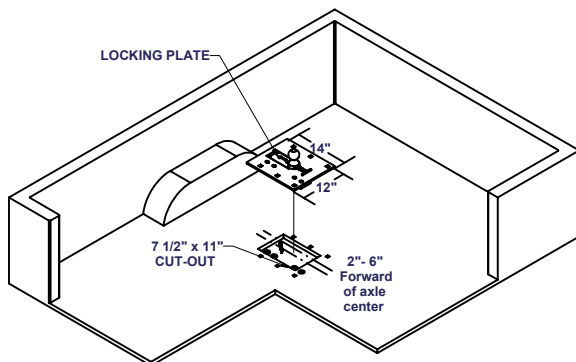

FIGURE 2

CAUTION: Check cut-out area for gas lines, brake lines, etc. before making cut-out or drilling any holes. It may be necessary to move the assembly, but you must keep the ball centered and 2"- 6" in front of the axle.

4. The hitch ball must be centered in the truck bed (**Figure 2**). Offset the cut-out to the drivers side keep the ball centered.
5. Make the cut-out as marked.
6. To properly transfer towing forces and to add strength, the hitch ball must be supported by a proper method which ties the hitch ball to the truck frame. CURT Manufacturing suggests one of the following two methods on the next pages or the purchase of a C-52 kit.

BED PLATE SUPPORT

The installer must make his/her own support consisting of a hot rolled steel plate, (3/8" x 26" x 40"), Angle braces (2" x 2") and frame brackets (3/8" x 2"). (**Figure 3**)

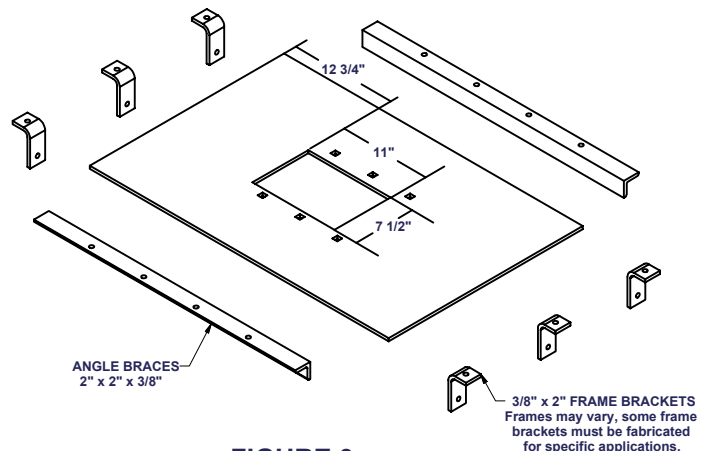

FIGURE 3

1. Center bed plate in the pickup bed. (**Figure 4**).
2. Center cut-out in bed with cut-out in plate.

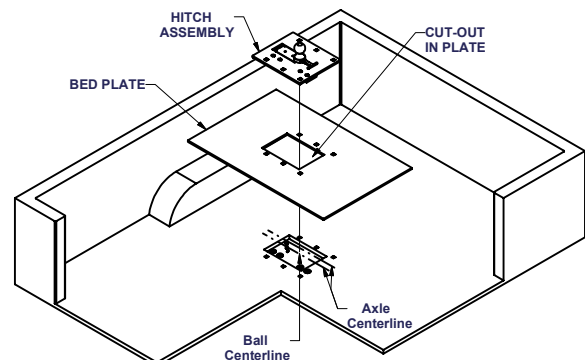

FIGURE 4

1/10/2008

3. Place assembly in hole, plate and bed.
4. Using holes in base of fold-down hitch as a template, mark and drill 11/16" holes through the bed and plate to secure hitch to bed plate.
5. Use 6 SAE grade 5, 5/8" carriage bolts and flange nuts to bolt the hitch ball assembly into the bed and through the plate. Shims should be used to accommodate corrugation in pickup bed.
6. Tighten nuts to 115 lb-ft. torque.
7. Attach angle braces to the underneath side of bed so bolts go through both the bed and the plate. If necessary, move angle braces forward or back to clear cross members.
8. Drill 17/32" holes in front and rear of plate. (Figure 5)

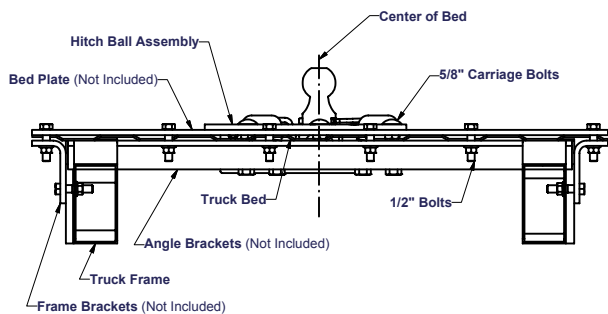

FIGURE 5

9. Use SAE grade 5, 1/2" bolts, nuts and lockwashers to attach angle braces.
10. Fabricate 6 frame brackets 2" x 3/8".
11. Place brackets along each side of truck frame taking care to avoid cross members or other parts. Drill 17/32" holes through bed and plate. (Figure 5)
12. Attach brackets to bed and plate with SAE grade 5, 1/2" bolts, nuts and lockwashers.
13. Drill 17/32" holes through lower angles of brackets and through the truck frame. (Figure 5) Holes must be in center of frame.
14. Bolt brackets to the frame with SAE grade 5, 1/2" bolts, nuts and lockwashers (Not supplied).

CAUTION: Do not weld brackets to frame.

15. Tighten all bolts to 75 lb-ft. torque.

FRAME SUPPORT

An alternative mounting method is the H-Frame support which consist of a steel frame and frame brackets. The steel bar for the framework should be at least 1/2" thick and 2" wide. The frame brackets should be 3/8" x 2".

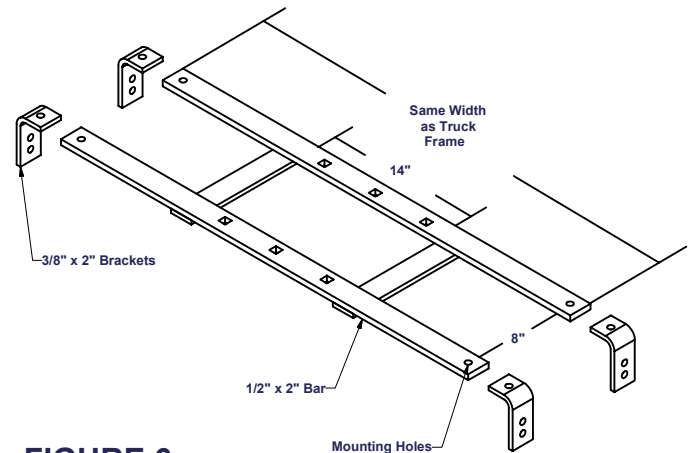
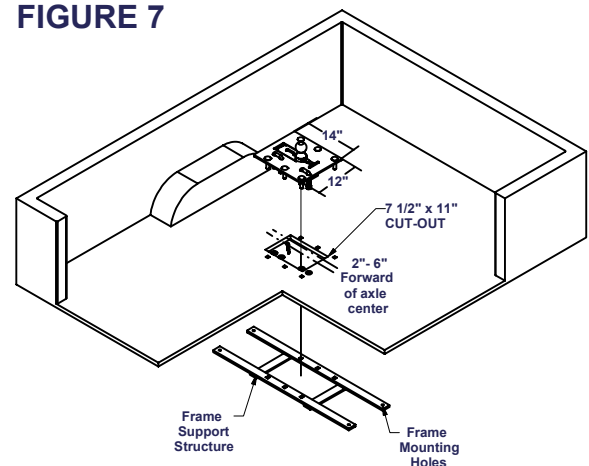

FIGURE 6

1. Align fold-down hitch ball assembly in bed of truck centered with cut-out in floor of bed.
2. Using the hitch ball assembly as a template, mark and drill 11/16" holes. (Figure 7)

FIGURE 7



3. Place frame support structure underneath bed of truck and above truck frame. Align with cut-out in bed of truck. Use clamps to hold structure in place.
4. Using holes previously drilled in truck bed as a guide, drill six holes in structure.

1/10/2008

- Using the SAE grade 5, 5/8" carriage bolts and flange nuts to attach the hitch ball assembly and the frame structure support to the truck bed. Shims should be used to accommodate corrugation in pickup bed.

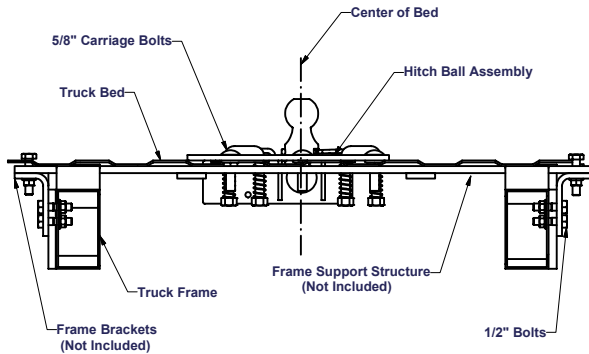

FIGURE 8

- Tighten to 115 lb-ft. torque.
- Fabricate four 3/8" x 2" steel frame brackets to fit your particular truck.
- Attach frame brackets to frame support structure and truck frame using SAE grade 5, 5/8" hex bolts, nuts and lockwashers.
- Tighten to 115 lb-ft. torque.

WARNING: Do not weld brackets to frame, welding will not provide the strength needed for towing.

PARTS LIST:

- (1) C-52 Folding Hitchball
- (6) 5/8-11 x 2 1/2" carriage bolts
- (6) 5/8-11 flange nuts
- (1) U-bolt kit (Included)

INSTALLATION CHECK

Raise the hitch ball and place the locking plate in position. Connect the trailer to the hitch ball, you should have about 6" clearance between bottom of trailer overhang and top of bed sides. Check clearance between trailer and vehicle at all corners.

OPERATION

- To raise ball into towing position, use handle to lift locking plate. The ball may then be lifted into the raised position by pulling the T-handle upward.
- Close the locking plate to lock the ball in place.
- To fold ball down when not in use, lift the locking plate, lower ball down and close locking plate.

MAINTENANCE

- Keep hitch ball greased regularly. Use wheel bearing grease to prevent wear and rust.
- Oil hinge points of locking plate at least every two months.
- Keep hitch assembly free of dirt and other foreign matter.
- Check tightness on all nuts and bolts before each use. Also check for excessive wear.
- Check for ball wear before each use. Do not tow trailer with worn or damaged parts.

**Thank You For Patronizing an American Company.
See us at a local dealer for all of your
hitch and trailer supplies.**

CAB TO TRAILER CLEARANCE

1/10/2008

REMOVAL OF REAR WINDOW ACCESSORIES MAY BE REQUIRED.

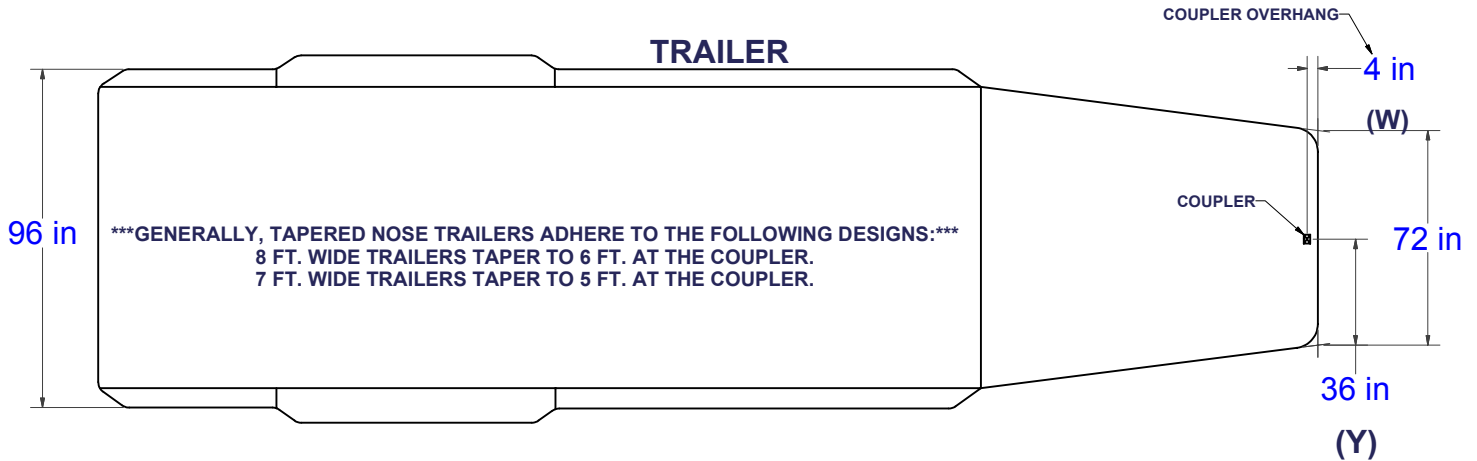

LONG & SHORT TRUCK BEDS

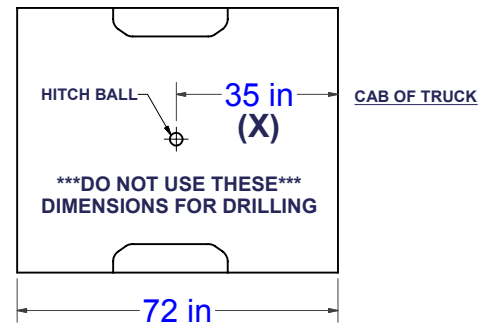
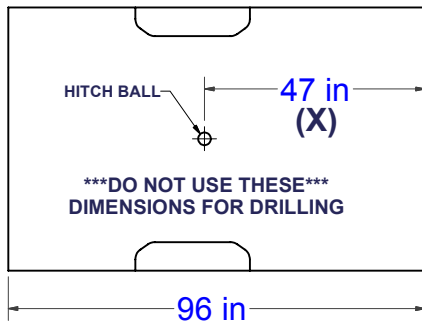

WARNING REFERENCE CLEARANCE CALCULATOR BEFORE TOWING

CLEARANCE CALCULATION

$$\begin{matrix} \text{(CAB TO BALL CENTER)} & - & 1/2 \text{ (TRAILER WIDTH)} & = & \text{(MINIMUM CLEARANCE)} \\ \text{(X)} & - & \text{(Y)} & = & \text{(Z)} \end{matrix}$$

IF THERE IS AN OVERHANG FROM THE COUPLER THEN THE EQUATION IS:

$$\text{[(X) - (W)]} - \text{(Y)} = \text{(Z)}$$

IF (Z) IS POSITIVE, TRAILER **WILL NOT** INTERFERE WITH CAB OF TRUCK.
 IF (Z) IS NEGATIVE, TRAILER **WILL** INTERFERE WITH CAB OF TRUCK!!!

EXAMPLE:

STANDARD TRAILER

$$X - Y = Z$$

$$35 - 36 = -1$$

(TRAILER **WILL INTERFERE** WITH CAB)

TRAILER WITH OVERHANG

$$\text{[(X) - (W)]} - Y = Z$$

$$[35 - 4] - 36 = -5$$

(TRAILER **WILL INTERFERE** WITH CAB)

YOUR CALCULATION:

(CAB TO BALL CENTER) _____

(COUPLER OVERHANG) _____

1/2 (TRAILER WIDTH) _____

(MINIMUM CLEARANCE) = _____